



**THAME**  
ENGINEERING

# SLOT/TENON DIAMOND & ALUMINIUM TOP JAWS TO SUIT QUICK JAW CHANGE CHUCKS

- Material : Steel : 080M15 Aluminium : HE30TF
- Black Finish

## DIAMOND TOP JAWS

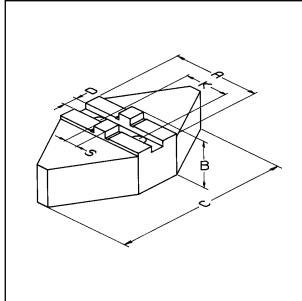

THAME PART No.	A	B	C	D	K	S	BOLT	WEIGHT KG/SET
<b>CQ 16</b> STEEL	60	60	120	8	32	18	M8	9.0
<b>HT 16</b> ALUMINIUM	64	64	120					3.8
<b>CQ 20</b> STEEL	76	64	150	10	40	20	M8	14.0
<b>HT 20</b> ALUMINIUM	76	64	150					5.9
<b>CQ 25</b> STEEL	89	64	170	12	40	20	M12	20.0
<b>HT 25</b> ALUMINIUM	89	64	170					8.4
<b>CQ 32</b> STEEL	118	76	240	12	54	26	M12	28.0
<b>HT 32</b> ALUMINIUM	118	76	240					10.5

## ALUMINIUM TOP JAWS

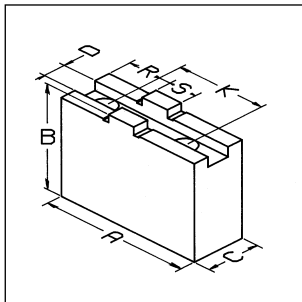

THAME PART No.	A	B	C	D	K	R	S	BOLT	WEIGHT KG/SET
<b>CW 16</b>	85	50	25	8	32	25	18	M8	0.7
<b>CW 20</b>	105	50	25	10	40	34	20	M8	0.9
<b>CW 25</b>	125	60	40	12	40	36	20	M12	2.0
<b>CW 32</b>	145	60	40	12	54	45	26	M12	2.4
<b>CW 40</b>	180	80	50	18	60	50	30	M16	5.1



**THAME**  
ENGINEERING

# To Suit Berg, Forkardt, Gamet, Kitagawa, Reishauer, Röhm, Schunk & SMW-Autoblok Quick Change Chucks

BERG	FORKARDT	GAMET	KITAGAWA	REISHAUER	RÖHM	SCHUNK	SMW-AUTOBLOK
KHNC 160 KHNC 185	F 160 KTNC 160 KTNCV 175 KTNCV 160 FNC 175	MX 152 MX 175		RHU 160	DURO 160 DURO NC 160 DURO NC 175 DURO NCE 160	ROTA-G 160 ROTA-S 160 ROTA-S plus 160 ROTA NC-W 185 THW 165 R	RMG 160 KNCS 160 KNCS 175 KNCS 170-43 KNCS -N 170-43 KNSP 160 HG 160 HG-F 160 HG-N 160
KHNC 200	F 200 KTNC 200 KTNCV 200 FNC 200	MX 215	QJ 8	RHU 200	DURO 200 DURO NC 200 DURO NCE 200	ROTA-G 200 ROTA-S 200 ROTA-S plus 200 ROTA NC-WF 210 ROTA NC-W 225 THW 210F THF 210 R	RMG 200 HG-F 210 HG 200 HG-N 210 KNSP 200 KNCS 200 KNCS 225 KNCS 210-52 KNCS-N 210-52 KNCS-N 225-65
KHNC 250 KHNC 315	F 250 KTNC 250 KTNC 280 KTNC 315 KTNCV 250 KTNCV 315 UNC 250/315 FNC 250/315	MX 252 MX 315 MX 330	QJ 10 QJ 12	RHU 250	DURO 250 DURO NC 250 DURO NCE 250 DURO NCE 315	ROTA-G 250 ROTA NC-WF 250 ROTA-S 250 ROTA-S plus 250 ROTA NC-W 265 ROTA-G 315 ROTA NC-W 315 ROTA NC-WF 315 THW 250 F/250 R THW 265 F/265 R THW 315 R	RMG 250 KNCS 250 KNCS 260 KNCS 260-71 KNCS 315 KNCS 315-91 KNCS-N 260-72 KNCS-N 315-91 HG 250/315 HG-F 260/315 HG-N 260/315
KHNC 400	F 315 KTNC 360 KTNC 400 KTNCV 400 UNC 400 FNC 400	MX 380		RHU 315	DURO 315 DURO NC 315 DURO NCE 315	ROTA-G 400 ROTA-S 315 ROTA-S plus 315 ROTA NC-W 400 THW 315 F/400 F THW 400 R	RMG 315 KNCS 400 HG 400 KNC 400 KNCS 400-120 KNCS-N 400-128 HG-N 400

BERG	FORKARDT	GAMET	KITAGAWA	REISHAUER	RÖHM	SCHUNK	SMW-AUTOBLOK
KHNC 160 KHNC 185	F 160 KTNC 160 KTNCV 175 KTNCV 160 FNC 175	MX 152 MX 175		RHU 160	DURO 160 DURO NC 160 DURO NC 175 DURO NCE 160	ROTA-G 160 ROTA-S 160 ROTA-S plus 160 KNCS 170-43 THW 165 R KNSP 160 HG 160	RMG 160 KNCS 160 KNCS 175 KNCS 170-43 KNCS -N 170-43 KNSP 160 HG 160 HG-F 160 HG-N 160
KHNC 200	F 200 KTNC 200 KTNCV 200 FNC 200	MX 215	QJ 8	RHU 200	DURO 200 DURO NC 200 DURO NCE 200	ROTA-G 200 ROTA-S 200 ROTA-S plus 200 ROTA NC-WF 210 ROTA NC-W 225 THW 210F THF 210 R KNCS 210-52 KNCS-N 210-52	RMG 200 HG 200 HG-F210 KNSP 200 HG-N210 KNCS 200 KNCS 225 KNCS 210-52 KNCS-N225-65 KNCS-N 210-52
KHNC 250 KHNC 315	F 250 KTNC 250 KTNC 280 KTNC 315 KTNCV 250 KTNCV 315 UNC 250/315 FNC 250/315	MX 252 MX 315 MX 330	QJ 10 QJ 12	RHU 250	DURO 250 DURO NC 250 DURO NCE 250 DURO NCE 315	ROTA-G 250 ROTA NC-WF 250 ROTA-S 250 ROTA-S plus 250 ROTA NC-W 265 ROTA-G 315 ROTA NC-W 315 ROTA NC-WF 315 THW 250 F/250 R THW 265 F/265 R THW 315 R	RMG 250 KNCS 250 KNCS 260 KNCS 315 HG-F250/315 KNCS 260-71 KNCS 315-91 HG-N260/315 KNCS-N 260-72 KNCS-N 315-91 HG 250/315
KHNC 400	F 315 KTNC 360 KTNC 400 KTNCV 400 UNC 400 FNC 400	MX 380		RHU 315	DURO 315 DURO NC 315 DURO NCE 400	ROTA-G 400 ROTA-S 315 ROTA-S plus 315 ROTA NC-W 400 THW 315 F/400 F THW 400 R	RMG 315 KNCS 400 KNCS 400-120 HG-N400 KNCS-N 400-128 HG 400 KNC 400
KHNC 500	F 400/500L UNC 500 KTNC 500 KTNC 630 KTNCV 500 KTNCV 630 FNC 500/630				DURO 400 DURO NC 400 DURO 500 DURO NC 500 DURO NCE 500		HG 500 HG-F 400/500 HG 630 KNCS 500 HG-N 500/600 HG 630 KNCS 500 KNCS 630 KNCS 500-160 KNCS-N 500-165 KNCS 630-160 KNCS-N 630-165