



THAME
ENGINEERING

SLOT/TENON HARD BASE JAWS

TO SUIT QUICK JAW CHANGE CHUCKS

TO SUIT FORKARDT, KITAGAWA, RÖHM, SMW & SCHUNK QUICK JAW CHANGE CHUCKS

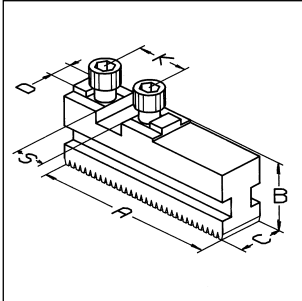

THAME PART No.	A	B	C	D	K	S	BOLT TYPE	WEIGHT KG/SET	FORKARDT	KITAGAWA	SCHUNK	RÖHM	SMW
MFG 160	74	27	20	8	32	18	M8	0.8	F 160 F+160 KTNC 160 KTNCV 175 FNC 175		Rota-S 160 Rota-S plus160	DURO 160 DURO NC 160 DURO NC 175 DURO NCE 160	HG-F160
MFG 200	90	32	22	10	40	20	M8	1.2	F 200 F+200 KTNC 200 KTNCV 200 FNC 200	QJ 08 QJ 210	THW 210-52F Rota-S 200 Rota-S plus 200 Rota NC-WF 210	DURO 200 DURO NC 200 DURO NCE 200 DURO NC 225	HG-F210
MFG 250	110	37	26	12	40	20	M12	2.0	F 250 F+250 UNC 250/ 315 KTNC 250/ 280/315 KTNCV 250/ 315 FNC 315	QJ 10 QJ 254 QJ 12 QJ 315	THW 250-65F THW265-71F Rota-S 250 Rota-S plus 250 Rota NC-WF 250 Rota NC-WF 315	DURO 250 DURO NC 250 DURO NCE 250 DURO NCE 315	HG-F260
MFG 315	125	43	32	12	54	26	M12	3.3	F 315 F+315 UNC 400 KTNC 360/ 400 KTNCV 400 FNC 400		THW 315 F THW 400-120F Rota-S 315 Rota-S plus 315	DURO 315 DURO NC 315 DURO NCE 400	HG-F315
MFG 400	160	51	45	18	60	30	M16	7.3	F 400, F500L UNC 500 KTNC 500/ 630 KTNCV 500/ 630 FNC 500/630 F+400		THW 500-128F Rota-S 400 Rota-S 500 Rota-S plus 400 Rota-S plus 500	DURO 400/500 DURO NC 400/ 500 DURO NCE 500	HG-F400 HG-F500

TO SUIT SMW-AUTOBLOK, REISHAUER & SCHUNK QUICK JAW CHANGE CHUCKS

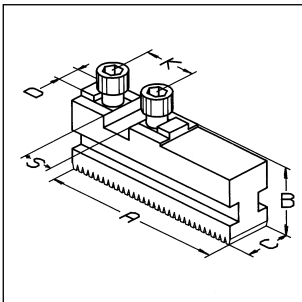

THAME PART No.	A	B	C	D	K	S	BOLT TYPE	WEIGHT KG/SET	SMW-AUTOBLOK	SCHUNK	REISHAUER	
GBK 140	56	27.5	20	8	32	18	M8	0.6	KNCS 140	KNCS-N140		
GBK 160	65	27.5	20	8	32	18	M8	0.7	KNCS 160/175 HG 160 KNCS-N-170	KNSP 160 RMG 160	THW165-37R Rota-G 160 Rota NC-W 185	RHU 160
GBK 200	85	29.5	22	10	40	20	M8	1.0	KNCS 200 HG 200 KNCS-N-210/225	KNSP 200 RMG 200	THW210-52R Rota-G 200 Rota NC-W 225	RHU 200
GBK 250	104	37	26	12	40	20	M12	1.8	KNCS 250/260 HG 250 KNCS-N 260	RMG 250	THW250-65R THW265-71R Rota NC-W 265 Rota-G 250	RHU 250
GBK 315	115	43	32	12	40	20	M12	2.7	KNCS 315 KNCS-N 315	HG 315	THW315-86R Rota-G 315 Rota NC-W 400	
GBK 400	125	43	32	12	54	26	M12	3.0	KNCS 400 RMG 315	HG 400 KNCS-N 400	THW400-120R Rota-G 400 Rota NC-W 400	RHU 315
GBK 500	160	57	45	18	60	30	M16	7.1	KNCS 500 KNCS-N 500	HG 500	THW500-128R Rota-G 500	
GBK 630	200	57	45	18	60	30	M16	9.0	KNCS 630 KNCS-N 630	HG 630	THW630-128R	

ALSO AVAILABLE - BERG & GAMET BASE JAWS AND EXTENDED LENGTH AND HALF PITCH TYPE JAWS





THAME
ENGINEERING

MONOBLOCK HARD REVERSIBLE JAWS TO SUIT QUICK JAW CHANGE CHUCKS

• Material : 590M17

TO SUIT FORKARDT, RÖHM, SMW-AUTOBLOK & SCHUNK QUICK JAW CHANGE CHUCKS

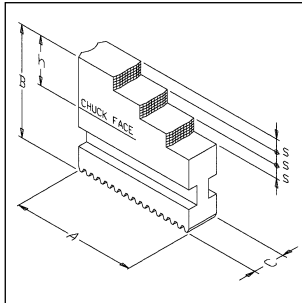

THAME PART No.	A	B	C	S	h	WEIGHT KG/SET	Forkardt	Röhm	SMW	Schunk
FST 16	79	45	20	7.5	24	1.1	F 160 F+160 KTNCV 175 KTNC 160 FNC 175	DURO 160 DURO-NC 160/175 DURO-NCE 160	HG-F 160	Rota-S 160 Rota-S plus 160
FST 20	94	60	22	10	35	1.9	F 200 F+200 KTNCV 200 KTNC 200 FNC 200	DURO 200 DURO-NC 200 DURO-NCE 200	HG-F 210	THW 210 F Rota-S 200 Rota-S plus 200 Rota NC-WF 210
FST 25	114	70	26	14	40	3.4	F 250 F+250 KTNCV 250 KTNCV 315 KTNC 250/280 KTNC 315 FNC 250/315	DURO 250 DURO-NC 250 DURO-NCE 250 DURO-NCE 315	HGF-260	THW 250 F THW 265 F Rota-S 250 Rota-S plus 250 Rota NC-WF 250 Rota NC-WF 315
FST 31	130	81	32	15	46	5.4	F 315 F+315 KTNCV 400 KTNC 360-400 FNC 400	DURO 315 DURO-NC 315 DURO-NCE 400	HG-F 315	THW 400 F Rota-S 315 THW 315 F Rota-S plus 315
FST 40	167	93	45	20	52	11.0	F 400 F+400 F 500L KTNCV 500 KTNCV 630 KTNC 500/630 FNC 500/630	DURO 400 DURO-NC 400 DURO 500 DURO-NC 500 DURO-NCE 500	HG-F 400 HG-F 500	THW 500 F Rota-S 400 Rota-S 500 Rota-S plus 400 Rota-S plus 500

TO SUIT SMW-AUTOBLOK, REISHAUER & SCHUNK QUICK JAW CHANGE CHUCKS

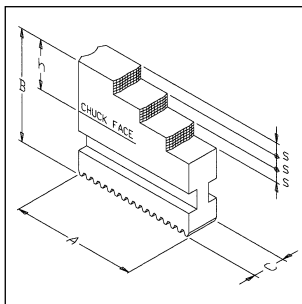

THAME PART No.	A	B	C	S	h	WEIGHT KG/SET	SMW-Autoblok	Reishauer	Schunk
GST 160-1	58	43.5	20	7	22	0.6	KNCS 140 KNCS 160 KNCSN 140 KNSP 160 RMG 160 HG 160	RHU 160	THW 160 R Rota-G 160 Rota NC-W185
GST 160-2							HGN 160 KNCS-N 176		
GST 170	65	43.5	20	7	23	0.7			
GST 200	75	51	22	8	26	1.2	KNCS 200 KNCSN 210 KNCSN 225 KNSP 200 RMG 200 HG 200 HGN 200	RHU 200	THW 210 R Rota-G 200 Rota NC-W225
GST 210	84	51	22	8	26	1.3			
GST 250	90	60	26	10	31	1.9	KNCS 250 KNCSN 260 RMG 250 HG 250 HGN 250	RHU 250	THW 250 R THW 265 R Rota-G 250 Rota NC-W265
GST 315	117	66	32	11	32	3.4	KNCS 315 KNCSN 315 HG 315 HGN 315		THW 315 R Rota-G 315 Rota NC-W315
GST 400	137	70	32	11	36	4.4	KNCS 400 KNCSN 400 RMG 315 HG 400 HGN 400	RHU 315	THW 400 R Rota-G 400 Rota NC-W400
GST 500	175	93	45	20	46	11.7	KNCS 500 KNCSN 500 HG 500 HGN 500 KNCS 630 KNCSN 630 HG 630 HGN 630		THW 500 R THW 600 R Rota-G 500



THAME
ENGINEERING

SOFT MONOBLOCK JAWS

TO SUIT QUICK JAW CHANGE CHUCKS

• Material : 080M40 (C45)

TO SUIT SMW-AUTOBLOK, REISHAUER & SCHUNK QUICK JAW CHANGE CHUCKS

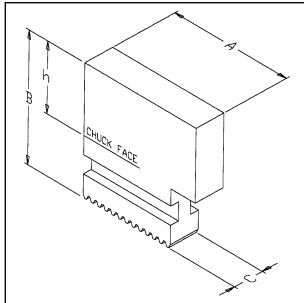

THAME PART No.	A	B	C	h	WEIGHT KG/SET	SMW-Autoblok	Reishauer	Schunk
UVB140	58	55.5	20	35	1.3	KNCS 140 KNCSN 140		
UVB170	65	55.5	20	35	1.4	KNCS 160 KNCS 175 KNCSN 170 KNSP 160 RMG 160 HG 160 HGN 160 KNCS-N170	RHU 160	THW 165 R Rota-G 160 Rota NC-W185
UVB200	77	65	22	40	2.0	KNCS 200 KNCSN 210 KNCSN 225 KNSP 200 RMG 200 HG 200 HGN 210	RHU 200	THW 210 R Rota-G 200 Rota NC-W225
UVB250	97	84	26	55	4.2	KNCS 250 KNCS 260 KNCSN 260 RMG 250 HG 250 HGN 260	RHU 250	THW 250 R THW 265 R Rota-G 250 Rota NC-W265
UVB315	118	90	32	56	6.6	KNCS 315 KNCSN 315 HG 315 HGN 315		THW 315 R Rota-G 315 Rota NC-W315
UVB400	145	100	32	66	9.0	KNCS 4000 KNCSN 400 RMG 315 HG 400 HGN 400	RHU 315	THW 400 R Rota-G 400 Rota NC-W400
UVB500	175	124	45	77	19.5	KNCS 500 KNCSN 500 HG 500 HGN 500		THW 500 R Rota-G 500
UVB600	230	134	45	87	27.5	KNCS 630 KNCSN 630 HG 630 HGN 630		THW 630 R

TO SUIT FORKARDT, RÖHM, SMW-AUTOBLOK & SCHUNK QUICK JAW CHANGE CHUCKS

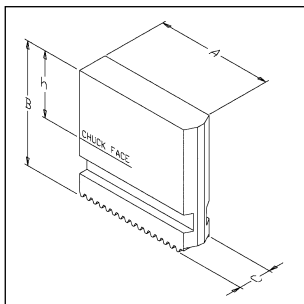

THAME PART No.	A	B	C	h	WEIGHT KG/SET	Forkardt	Röhm	Schunk	SMW
FVB 170	79	45	20	24	1.4	F 160 F+160 KTNC 160 KTNCV 175 FNC 175	DURO 160 DURO-NC 160 DURO-NC 175 DURO-NCE 160	Rota-S 160 Rota-S plus 160	HGF 160
FVB 200	94	60	22	35	2.5	F 200 F+200 KTNC 200 KTNCV 200 FNC 200	DURO 200 DURO-NC 200 DURO-NCE 200	THW 210 F Rota-S 200 Rota-S plus 200 Rota NC-WF 210	HGF 210
FVB 201	94	80	22	55	2.8				
FVB 250	115	70	26	40	4.3	F 250 F+250 KTNC 250/280/315 KTNCV 250/315 UNC 250/315 FNC 250/315	DURO 250 DURO-NC 250 DURO-NCE 250/315	THW 250-F THW 265-F Rota-S 250 Rota-S plus 250 RotaNC-WF 250 Rota NC-WF 315	HG-F 260
FVB 251	115	100	26	75	4.8				
FVB 315	140	81	32	46	7.3	F 315 F+315 KTNC 360/400 KTNCV 400 UNC 400 FNC 400	DURO 315 DURO-NC 315 DURO-NCE 400	THW 400 F Rota-S 315 THW 315 F Rota-S plus 315	HGF 315
FVB 400	176	93	45	53	15.8	F 400/500E F+400 KTNC 500/630 KTNCV 500/630 UNC 500 FNC 500/630	DURO 400/500 DURO NC 400/500 DURO NCE 500	THW 500 F Rota-S 400 Rota-S 500 Rota-S plus 400 Rota-S plus 500	HGF 400 HGF 500



SERRATED HARD BASE JAWS

TO SUIT QUICK CHANGE AND OTHER POWER CHUCKS

QUICK CHANGE BASE JAWS



Suitable base jaws for Quick Change Power Chucks taking serrated top jaws can be supplied, such as the Pratt Burnerd Quick Change High Speed Power Chucks, Autoblok RCD Quick Jaw Change Power Chucks, etc.

REPLACEMENT BASE JAWS

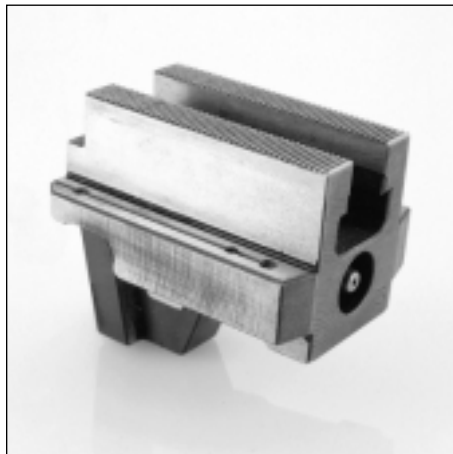

Replacement base jaws for many makes of chucks can be supplied on request - Autoblok, Berg, Forkardt, Gamet, Howa, Kitagawa, Matsumoto, Pratt Burnerd, Röhms, SMW and others.

SPECIAL BASE JAWS

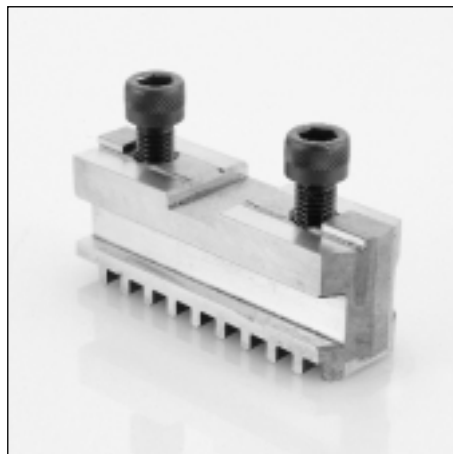

We can design and manufacture all types of special base jaws to suit different chuck types and other special applications, please consult our design office.